

# MERCER

by Danao Studio



POUF 73"

064.7505

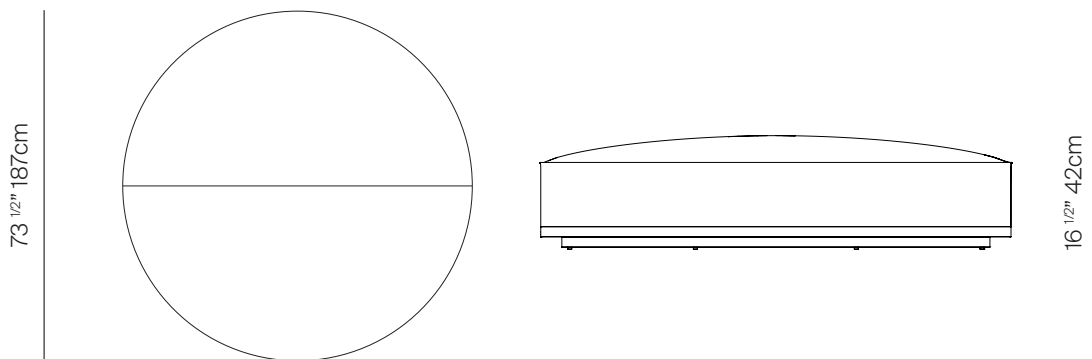

## SPECIFICATIONS

Width:	73 1/2"	187 cm
Depth:	73 1/2"	187 cm
Height:	16 1/2"	42 cm
Seat height:	16 1/2"	42 cm
COM:	5 1/2 yds	

COM based on 54" wide no repeat fabric.

## MATERIALS

Frame: Powder coated aluminum.

Cushion foam: Made of HR (high resiliency) foam with Dacron wrap incased in a nonwoven UV stabilized waterproof sonic welded fabric.

Cushion fabric: COM/Outdoor Canvas Grade A / Grade B

Fabric options.

Furniture cover available.

## FINISHES

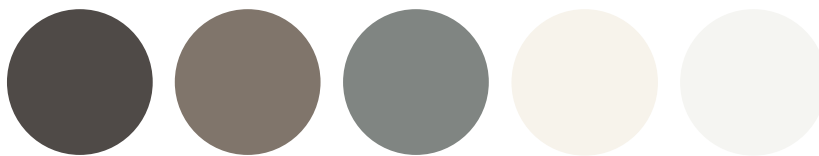

SPACE GREY  
-52

MUSCADE  
-51

STONE  
-43

SHELL  
-45

SPACE GREY  
-53

ALUMINUM

MOQ APPLIED ON CERTAIN FINISHES

TRHOW PILLOWS SOLD SEPARATELY

# DANA O

[danaoliving.com](http://danaoliving.com)

POUF 73"

064.7505

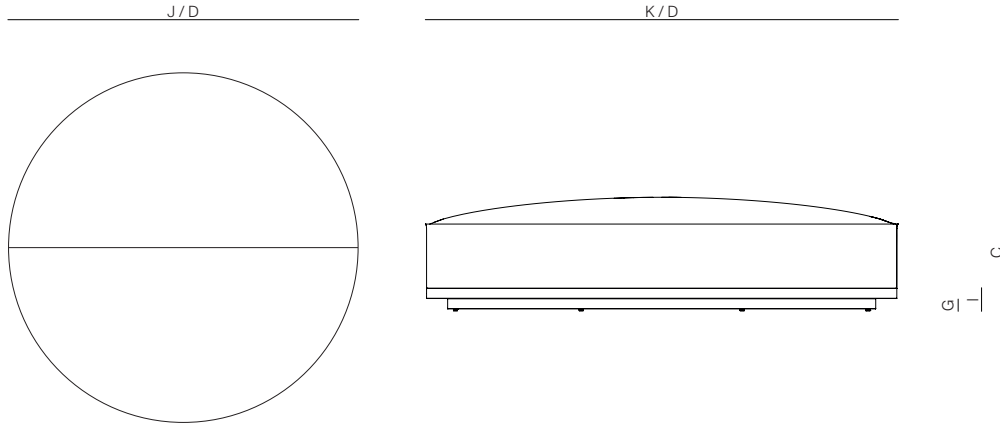

MEASURES INCH CM	OVERALL WIDTH	OVERALL DEPTH	OVERALL HEIGHT WITH CUSHIONS	DIAMETER	FOOT HEIGHT	FRAME SEAT HEIGHT (FLOOR TO FRAME)	INSIDE SEAT WIDTH	INSIDE SEAT DEPTH
DESCRIPTION	A	B	C	D	G	I	J	K
POUF 73"	-	-	16 1/2	73 1/2	11/2	3 1/2	73 1/2	73 1/2
SKU# 064.7505	-	-	42	187	4	8.8	187	187

MEASURES INCH CM	# OF BACK CUSHIONS	# OF SEAT CUSHIONS	COM YARDS METERS	DIAGONAL CLEARANCE	FURNITURE WEIGHT LBS KGS	TOTAL PIECES IN A BOX	BOXED WEIGHT LBS KGS	CUBE
DESCRIPTION	L							
POUF 73"	1	1	11 3/4	74 3/4	69.8	1	85.2	20.3
SKU# 064.7505	1	1		189.8	31.64	1	38.64	

TRHAW PILLOWS SOLD SEPARATELY