

# MERCER

by Danao Studio



POUF 23"

064.7503

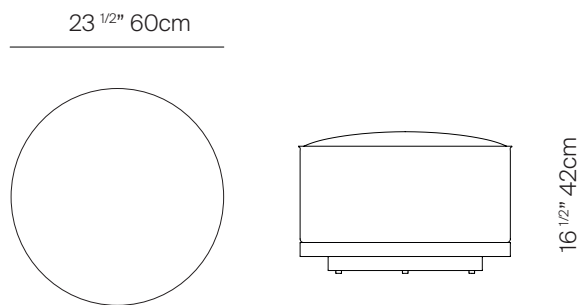

## SPECIFICATIONS

Width:	23 1/2"	60 cm
Depth:	23 1/2"	60 cm
Height:	16 1/2"	42 cm
Seat height:	16 1/2"	42 cm
COM:	2 1/2 yds	

COM based on 54" wide no repeat fabric.

## MATERIALS

Frame: Powder coated aluminum.

Cushion foam: Made of HR (high resiliency) foam with Dacron wrap incased in a nonwoven UV stabilized waterproof sonic welded fabric.

Cushion fabric: COM/Outdoor Canvas Grade A / Grade B

Fabric options.

Furniture cover available.

## FINISHES

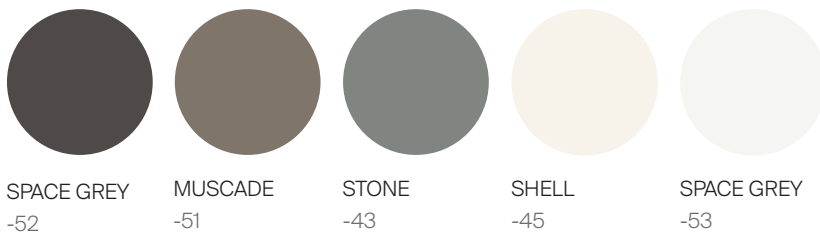

ALUMINUM

MOQ APPLIED ON CERTAIN FINISHES

TRHOW PILLOWS SOLD SEPARATELY

# DANA O

[danaoliving.com](http://danaoliving.com)

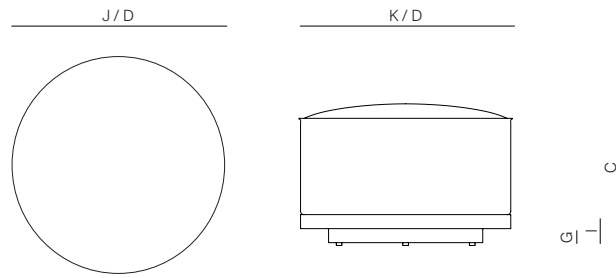

MEASURES INCH CM	OVERALL WIDTH	OVERALL DEPTH	OVERALL HEIGHT WITH CUSHIONS	DIAMETER	FOOT HEIGHT	FRAME SEAT HEIGHT (FLOOR TO FRAME)	INSIDE SEAT WIDTH	INSIDE SEAT DEPTH
DESCRIPTION	A	B	C	D	G	I	J	K
POUF 23"	-	-	16 1/2	23 1/2	11/2	3 1/2	23 1/2	23 1/2
SKU# 064.7503	-	-	42	60	4	8.8	60	60

MEASURES INCH CM	# OF BACK CUSHIONS	# OF SEAT CUSHIONS	COM YARDS METERS	DIAGONAL CLEARANCE	FURNITURE WEIGHT LBS KGS	TOTAL PIECES IN A BOX	BOXED WEIGHT LBS KGS	CUBE
DESCRIPTION	L							
POUF 23"	1	1	2 1/2	27 1/2	99	1	14.8	3.07
SKU# 064.7503	1	1		70	4.4	1	6.7	

TRH OW PILLOWS SOLD SEPARATELY